

SWR  
POWER METER

---

**Operation**  
**Manual**

## CONTENTS

A. INTRODUCTION.....	1
B. DESCRIPTION.....	1
C. FEATURES.....	2
D. SPECIFICATIONS.....	2
E. APPLICATIONS DRAWING.....	4
F. OPERATION INSTRUCTION.....	6
G. THE EXPLANATION OF CALIBRATION POINT.....	8
H. CIRCUIT DIAGRAM.....	8

## A. INTRODUCTION:

This manual contains operation instructions as well as the installation procedures in conjunction with transceiver, SWR/POWER METER and antenna.

## B. DESCRIPTION:

The Model 300 series of VSWR/RF POWER METERS are now widely used for both hobby and professional applications where accuracy and reliability are essential.

They provide the cost effective answer to VSWR, RF POWER and coaxial line measurements from 1.8MHz to 520MHz (Model 310 from 1.8MHz-150MHz, Model 320 from 130MHz-520MHz, Model 330 from 1.8MHz-520MHz).

Each meter employs one or more special wide-band sensors for flat frequency response and direct in-line power readings.

Both RMS and peak power level can be measured in switched ranges.

Generously rated, their high sensitivity enables them to cope with accuracy well at low power levels.

### C. FEATURES:

- \*Location:compact size in Line Watt meter thus in operation at any location.
- \*S.W.R.:Measurable SWR from minimum power 4w to maximum 200w.
- \*Peak Power:Measurable modulate power in operation of SSB mode.
- \*Accuracy:Linear characteristics assure accurate measuring over entire frequency range.
- \*Low Insertion loss:Less than 0.2dB.

### D. SPECIFICATIONS:

#### 1. Model:310

Frequency Range: 1.8 ~ 150MHz

Measurable Power Range: 0 ~ 200w

Power Range: 4w/20w/200w

Power Measurement Accuracy:

4w RANGE  $\pm 10\%$ (on full scale)

20w RANGE  $\pm 5\%$ (on full scale)

200w RANGE  $\pm 5\%$ (on full scale)

Note:220 ~ 420MHz add -10% F.S.

450 ~ 520MHz add +10% F.S.

Minimum Power for SWR Measurement: 4w  
SWR Measurement: 1.0 ~ ∞  
Insertion Loss: Less than 0.2dB  
Input/Output Impedance: 50 ohms  
Input/Output Connection Plugs: SO ~ 239

## 2. Model: 320

Frequency Range: 130 ~ 520MHz  
Measurable Power Range: 0 ~ 200w  
Power Range: 4w/20w/200w  
Power Measurement Accuracy:

4w RANGE ± 10%(on full scale)  
20w RANGE ± 5%(on full scale)  
200w RANGE ± 5%(on full scale)  
Note: 220 ~ 420MHz add -10% F.S.  
450 ~ 520MHz add +10% F.S.

Minimum Power for SWR Measurement: 4w  
SWR Measurement: 1.0 ~ ∞  
Insertion Loss: 130 ~ 250MHz Less than 0.1dB  
400 ~ 470MHz Less than 0.2dB  
520MHz Less than 0.3dB  
Input/Output Impedance: 50 ohms  
Input/Output Connection Plugs: SO ~ 239

### 3. Model: 330

Frequency Range:	1.8 ~ 520MHz
Measurable Power Range:	0 ~ 200w
Power Range:	4w/20w/200w
Power Measurement Accuracy:	
	4w RANGE $\pm 10\%$ (on full scale)
	20w RANGE $\pm 5\%$ (on full scale)
	200w RANGE $\pm 5\%$ (on full scale)
	Note: 220 ~ 420MHz add -10% F.S.
	450 ~ 520MHz add +10% F.S.
Minimum Power for SWR Measurement:	4w
SWR Measurement:	1.0 ~ $\infty$
Insertion Loss:	140 ~ 250MHz Less than 0.1dB
	400 ~ 470MHz Less than 0.2dB
	520MHz Less than 0.3dB
Input/Output Impedance:	50 ohms
Input/Output Connection Plugs:	SO ~ 239

E. Applications drawing in conjunction with Model 300 serie  
SWR/POWER METER to transceiver and antenna.

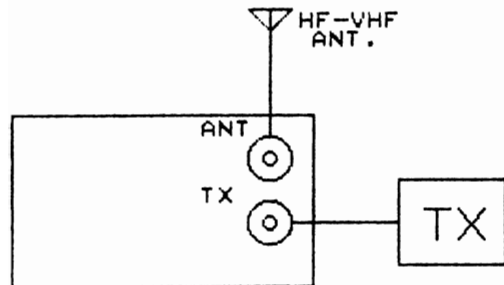

FIGURE 1

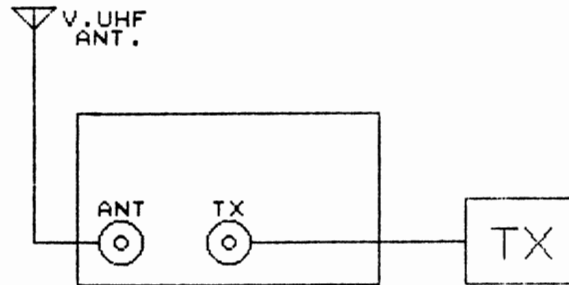

FIGURE 2

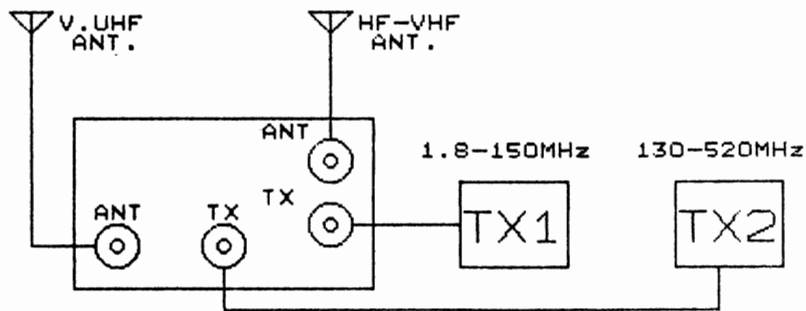

FIGURE 3

## F. OPERATION INSTRUCTION:

1. Turn the transceiver off. Disconnect the antenna coaxial cable from the transceiver output.
2. Connect the unit "ANT" connector located in the rear side of the unit to antenna connector, and, connect the unit "TX" to transceiver output.

For Model 330, Please make sure that the "POWER SWITCH" on the front panel is set on the proper using frequency band 150MHz or 520MHz position.

3. For measuring transmitting power rate, please put "FUNCTION SWITCH" of the front panel on "POWER" position and "RANGE SWITCH" on the suitable power range 200w, 20w or 4w section.

Also, set the "POWER SWITCH" on "FWD" position for reading the FORWARD power rate and set the "POWER SWITCH" on "REF" position for reading the "REFLECTIVE" power rate (only for Mode 310, and 320).

And then, when the transceiver switch is on, the meter needle will deflect.

Read the amount of deflection on the top scale. Never disconnect the "ANT" connector when transmitting. The abnormal voltage generated may damage the transceiver.

4. For measuring VSWR, at first, set "CAL" adjustable knob on "MIN" position.

Setting "FUNCTION SWITCH" on "CAL" position turning the transceiver output on, rotate clockwise the ":CAL" knob slowly for the full scale. Setting the meter needle to the suitable power rate calibration point "CAL SET" as following drawing. There are three different calibration points indicated on the meter.



calibration point for power rate 200-20w

calibration point for power rate 10w

(20-10w)

calibration point for power rate below 5w

Next, set the "FUNCTION SWITCH" on "SWR" position and read the meter scale. The meter will give the SWR reading directly.

#### G. The explanation of calibration point.

For the purpose of measuring the best accurating power and SWR, the unit adopts the three dividing calibration points as:

- (1) Power rate below 5w.
- (2) power rate below 20w.
- (3) power rate over 20w to 200w which are showed on the scale meter of the unit.

The different three calibration points are separatlcy used to be depend on the different transceiver output power rate accordingly.

#### H. CIRCUIT DIAGRAM

