



**AUTOMOTIVE
TESTER**

DM-9030

**OPERATION
MANUAL**

TABLE OF CONTENTS

Caution Symbol

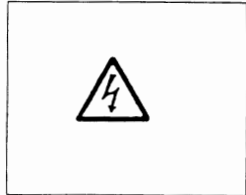

Caution :

- * Risk of electric shock !

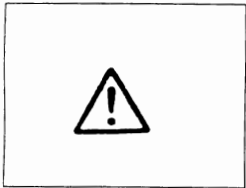

Caution :

- * Do not apply the overload voltage, current to the input terminal !
- * Remove test leads before open the battery cover !

Environment Conditions

- * Installation categories II .
- * Pollution Degree 2.
- * Altitude up to 2000 meters.
- * Indoor use.
- * Relative humidity 80% max.

1. FEATURES	1
2. SPECIFICATIONS.....	2
2-1 General Specifications	2
2-2 Electrical Specifications.....	3
3. FRONT PANEL DESCRIPTION.....	6
3-1 Display.....	6
3-2 AC/DC Switch.....	6
3-3 Power ON/OFF switch	6
3-4 Function Switch	6
3-5 Temperature Probe Socket	6
3-6 Input Terminal	6
3-7 Battery compartment.....	6
4. PRECAUTIONS & PREPARATIONS FOR MEASUREMENT	7
5. MEASURING PROCEDURE	7
5-1 Voltage Measurement	7
5-2 Current Measurement	10
5-3 Resistance Measurement	10
5-4 Temperature Measurement	11
5-5 Frequency Measurement	11
5-6 " RPM (TACH.) " Measurement	11
5-7 "DWELL ANGLE" Measurement	13
5-8 Continuity Beeper	14
5-9 Diode Check.....	14
5-10 OP ADPT./Optional Adapter (External Adapter).....	15
6. REPLACEMENT OF BATTERY	15
7. OPTIONAL TEMPERATURE PROBE & OTHER ACCESSORIES	16

1. FEATURES



- * Multi function measurement. DCV, ACV, DCA, ACA, OHMS, TEMPERATURE, Hz, RPM, DWELL ANGLE, DIODE, CONTINUITY BEEPER.
- * RPM (TACH) measurement by inductive pickup for more convenient & accurate readings of both conventional and distributorless ignitions.
- * RPM (TACH) used the " Secondary Tach. " measuring method, no matter what cylinder no is.
- * Accurate DCV/ACV, DCA/ACA and resistance measurement, wide range of automotive electronics tests.
- * Duty cycle (%) with Dwell conversion chart for electronic fuel injection and feedback carburetors.
- * Diode test quickly measures the forward bias voltage drop of alternator rectifiers and other diodes.
- * Continuity beeper keeps whenever probes touch a continuous circuit. Helps find shorts and open wires.
- * 10 Mega ohm impedance protects Mega ohm computer ckt.
- * Frequency measurements with adjustable trigger point for testing MAF, MAP & ABS SENSOR.
- * Rotary function switch, easy operation.
- * Large size LCD display.
- * Built-in overload protection for most ranges.



2. SPECIFICATIONS

2-1 General Specifications

Display	18 mm (0.7") LCD, 3 1/2 digits, Max. indication ± 1999 .
Measurement	36 ranges covering : DCV, ACV, DCA, ACA, OHMS, TEMPERATURE, Hz, RPM, DWELL ANGLE, DIODE, CONTINUITY BEEPER.
Polarity	Automatic Switching , "-" indicates negative polarity.
Zero Adjustment	Automatic
Over-input	Display shows "1" or "- 1".
Sampling time	Approx. 0.4 second.
Operating Temp.	0°C to 50°C (32°F to 122°F)
Operating Humidity	Less than 80% RH
Power Consumption	Approx. DC 3.6 mA.
Dimension	185 x 87 x 39 mm(7.3 x 3.4 x 1.5 inch)
Weight	322 g/0.71 LB (including battery).
Standard Accessories	Red and Black Test leads..... 1 pair Instruction Manual1 PC
Optional Accessories	RPM inductive pick up sensor (IP-07) Temperature probe, carrying case...

2-2 Electrical Specifications (23 ± 5°C)

DC VOLTAGE				
RANGE	ACCURACY	RESOLUTION	INPUT IMPEDANCE	OVERLOAD PROTECTION
200mV	± (0.5%+1d)	100uV	10M ohm	500V DC, 350V AC, 15 sec. 
2V	± (0.8%+1d)	1mV		DC ± 600 V AC 600 V 
20V		10mV		
200V		100mV		
600V		1V		

AC VOLTAGE				
RANGE	ACCURACY	RESOLUTION	INPUT IMPEDANCE	OVERLOAD PROTECTION
200mV	± (1%+2d)	100uV	10M ohm	500V DC, 350V AC, 15 sec 
2V (0.01V-2V)		1mV		DC ± 600 V AC 600 V 
20V		10mV		
200V		100mV		
600V		1V		

AC/DC CURRENT				
RANGE	ACCURACY	RESOLUTION	VOLTAGE DROP	OVERLOAD PROTECTION
10A	DCA: ± (1.5%+2d) ACA: ± (1.5%+3d)	10mA	ACA: AC200mV DCA: DC200mV	10A (UN FUSED) 

RESISTANCE				
RANGE	ACCURACY	RESOLUTION	OPEN CKT. VOLTAGE	OVERLOAD PROTECTION
200 ohm	± (1%+3d)	0.1 ohm	3 V Max. APPROX. 0.3 V Max.	AC 500V (Protected by PTC) 
2K		1 ohm		
20K		10 ohm		
200K		100 ohm		
2000K		1K ohm		
20M	± (2%+2d)	10K ohm		

DWEILL				
CYLINDER	RANGE	RESOLUTION	ACCURACY	OVERLOAD PROTECTION
3 CYL	0 - 120 °	0.1 °	± (1.2%+1d)	200V DC/AC RMS (within 15 sec) 
4 CYL	0 - 90 °			
5 CYL	0 - 72 °			
6 CYL	0 - 60 °			
8 CYL	0 - 45 °			
DUTY CYCLE	0 - 100.0 %	0.1 %		

TACH (Secondary tach, no matter what you, no. is)			
RANGE	RESOLUTION	ACCURACY	OVERLOAD PROTECTION
500 – 10,000 RPM	10 RPM	$\pm(1.2\%+1d)$	24V DC/AC RMS (within 1 min.) 

TEMPERATURE		
RANGE	RESOLUTION	ACCURACY
-20°C to 750°C	1°C	$\pm(1\% + 2d)$: 0 to 300 °C $\pm(3\% + 2d)$: Over 300 °C
0°F to 1400°F	1°F	$\pm(1\% + 3d)$: 0 to 550 °F $\pm(3\% + 3d)$: Over 550 °F

FREQUENCY (Hz)				
RANGE	MEASURING RANGE	ACCURACY	RESOLUTION	INPUT SENSITIVITY
200Hz	9–199.9 Hz	$\pm(1\%)$	0.1 Hz	35mV RMS
2 KHz	9–1999 Hz		1Hz	
20KHz	0.9–19.99 kHz		10Hz	

* Max. input voltage is 500 V DC/AC.



CONTINUITY BEEPER
A continuity test beeper is standard. When make the circuits checking for shorts or opens, it not necessary to look at the meter, the beeper sounds if continuity is present.

DIODE TEST
Open circuit voltage is approx. DC 3V max.

OPTIONAL ADAPTER (OP ADPT)			
RANGE	MAX. DISPLAY CAPACITY	PER DIGIT EQUAL:	ACCURACY
EXT ADPT	2000 x 1	0.1 mV DC	$\pm(1.2\% + 2d)$
200 A	200.0 x 0.1	0.1 mV DC	
2000 A	2000 x 1	1 mV DC	
BATT TEST	200.0 x 0.1	0.1 V DC	

3. FRONT PANEL DESCRIPTION

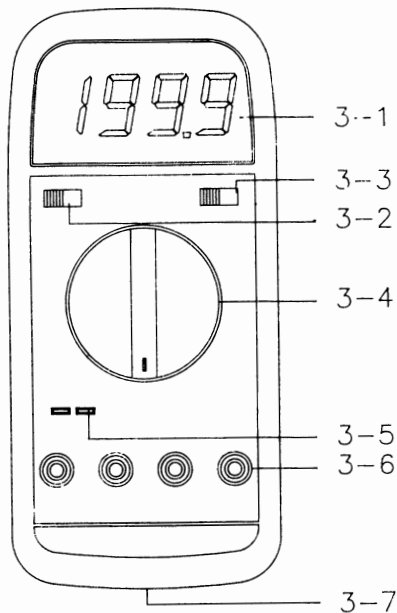



Fig. 1

- 3-1 Display
- 3-2 AC/DC Switch
- 3-3 Power ON/OFF switch
- 3-4 Function Switch
- 3-5 Temperature Probe Socket
- 3-6 Input Terminal
- 3-7 Battery compartment

Symbol :

AC = 
 DC = 
 Power On = 1
 Power Off = 0

4. PRECAUTIONS & PREPARATIONS FOR MEASUREMENT

- 1) Ensure that the DC 9V battery is connected correctly to its snap terminal and placed into the battery compartment.
- 2) Select the correct position of "Function Switch" & "AC/DC Switch" before making measurements.
- 3) Place the RED Test Lead into the proper input terminal before making measurements.
- 4) When make measurement, selecting the proper measurement range by starting at the largest anticipated value and progressively selecting lower ranges the measurement falls within the proper range.
- 5) Remove either of the test leads from the circuit under test when changing the measurement range.
- 6) Operate the instrument only in the ambient temperature range of 32 – 122°F (0 – 50°C) and less than 80 % relative humidity.
- 7) Do not exceed the maximum rated voltage of each range and input terminal.
- 8) Slide the "Power ON/OFF" always to the "OFF" position when the instrument does not use. Remove the battery if the instrument intend not be used for a long period of time.

5. MEASURING PROCEDURE

5-1 Voltage Measurement

- 1) Connect red test lead to "V" input terminal and black test lead to "COM" input terminal.
- 2) A. If voltage to be measured is AC, select "AC/DC Switch" to the "AC" position.
B. If voltage to be measured is DC, select "AC/DC Switch" to the "DC" position.

- 3) Determine the highest anticipated voltage (200mV, 2V, 20V, 200V, 600V) on the "Function Switch" and select to the corresponding position.
- 4) Connect test lead probes into circuit under test.
- 5) APPLICATION 1 : to check the "POINTS" condition:
(Used the DC 2V range)
 - a. Disconnect "HIGH TENSION WIRE" from distribution cape & ground " HIGH TENSION WIRE" by laying or taping lug to bare metal surface.
 - b. Connect RED TEST PROBE to " - " terminal of ignition coil (or points).
 - c. Turn ignition switch to ON for a while. Display values should indicate in LOW voltage value (should under 1 V). If not, bump engine until it reach.
 - d. If the above (c) point voltage display showed lower than 0.2V, then the contact resistance of " Points " is normal, or it need to be changed.
- 6) APPLICATION 2 : to check the " BATTERY LEAKAGE " condition (Used the DC 2V range)
 - a. Connect BLACK TEST PROBE to NEG (-) battery. Connect RED TEST PROBE to various spots on the surface of battery.
 - b. If display indicate some value, then there is Battery Leakage. Then clean acid or dirt from area around battery with baking soda and water solution. Wipe dry.
- 7) APPLICATION 3 : to check the " BATTERY LIGHT LOAD " (Used the DC 200V or 20V range)
 - a. Connect BLACK TEST PROBE to NEG (-) battery, Connect RED TEST PROBE to POS (+) battery terminal.

- b. Turn headlight switch on.
Turn high beam switch on.
Turn ignition switch on.
Turn heater switch on.
Turn radio on.
 - c. Do not continue above procedures for more than 2 minutes
 - d. Check that display reading is greater than 11.7 volts. If reading is not correct, battery should be charged or replaced.
- 8) APPLICATION 4 : to check the " BATTERY CAPACITY " (Used the DC 200V or 20V range)
- a. Disconnect " HIGH TENSION WIRE " from distribution cap. & ground " HIGH TENSION WIRE " by laying or taping lug to bare metal surface.
 - b. Connect BLACK TEST PROBE to NEG (-) battery terminal, Connect RED TEST PROBE to POS (+) battery terminal.
 - c. After cranking engine for about 15 seconds, check the display reading is greater than 9.1 volts. If reading is not correct, start motor should be checked or battery should be charged or replaced.
- 9) APPLICATION 5 : to check the " BATTERY CABLE " : (Used the DC 2V range). Measure the across voltage of " BATTERY CABLE " when cranking the engine to check the condition of " BATTERY CABLE "
- 10) OTHER DCV RANGE APPLICATION :
- a. Check Charging System.
 - b. Check Voltage Regulator

5-2 Current Measurement

- 1) Connect red test lead to "10A" input terminal and black test lead to " COM " input terminal.
- 2) A. If current to be measured is AC, select " AC/DC Switch " to the " AC " position.
B. If current to be measured is DC, select " AC/DC Switch " to the " DC " position.
- 3) Select the " Function Switch " to the " 10 A " position.
- 4) Open the circuit in which current is to be measured. Now securely connect test leads in series with the load in which the current is to be measured.

5-3 Resistance Measurement

- 1) Connect red test lead to " OHM " input terminal and black test lead to " COM " input terminal.
- 2) Determine the highest anticipated resistance (200OHM, 2K, 20K, 200K, 2000K or 20 M (K = 1000)) on the " function switch " and select to the corresponding position.
- 3) If the resistance being measured is connected to a circuit, turn off power to circuit being tested and discharge all capacitors.
- 4) Connect test lead probes into circuit (resistance) under test.
- 5) Read resistance value on digital display.
- 6) APPLICATION 1 : " 2K, 200K RANGE " to measure the coil's resistance.
- 7) APPLICATION 2 : " 2M RANGE " to measure whether the " CAPACITOR " is good or not.

5-4 Temperature Measurement

- 1) Insert the plug of the Thermocouple Probe (optional) into the " Temperature Probe Socket " (3-5, fig 1), take care to observe the correct polarity.
- 2) Determine the °C or °F on the " Function Switch " and select to the corresponding position.
- 3) **Consideration:**

When the Thermocouple Probe is first plugged into the meter, or if the probe is changed, the plug must be allowed to stabilize at the same temperature of the socket, which is in thermal contact with the cold junction compensation device, if greatest accuracy is to be achieved. This will only take a couple of minutes and only applies if the plug of probe has previously been exposed to an ambient temperature different of that meter.

5-5 Frequency Measurement

- 1) Connect black test lead to " COM " terminal and red test lead into "Hz" terminal.
- 2) Determine the highest anticipated frequency (200 Hz, 2K Hz 20K Hz) on the " Function Switch " and select to its corresponding position.
- 3) Connect test lead probes into circuit under test.

5-6 "RPM (TACH.)" Measurement

- 1) RPM measurement is with INDUCTIVE PICKUP SENSOR, IP-07 (Optional).
- 2) Connect above INDUCTIVE PICK UP Sensor's black test lead into " COM " terminal and red test lead into " TACH " terminal.

- 3) Select the " Function Switch " to the " RPM " position.
- 4) Connect the RPM INDUCTIVE PICK UP SENSOR to the HIGH TENSION WIRE of No. 1 SPARK PLUG (or No. 2, No. 3... SPARK PLUG), ref. Fig 2, then the display will show RPM reading (x 10 RPM).

NOTE:

- a. RPM (TACH) used the "Secondary Tech" measuring method, no matter what cylinder is
- b. If the display reading is unstable, it may be caused by environment interference. Please readjust the position of RPM INDUCTIVE PICK UP SENSOR or changed the direction of INDUCTIVE CLAMPS.

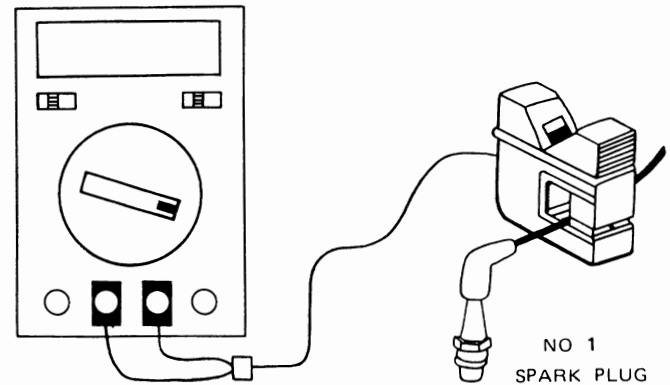

Fig 2

5-7 "DWELL ANGLE" Measurement

- 1) Select the "Function Switch" to the % (duty cycle), 3 cyl, 4 cyl, 5 cyl, 6 cyl on the DWELL range.
- 2) Connect black test lead into "COM" terminal and red test lead into "DWELL" terminal.
- 3) Connect red test probe into "BREAKER POINTS" or "-" terminal of IGNITION COIL.
Connect black test probe into "GROUND" or "-" terminal of battery.

* The wire connection diagram please ref. fig. 3.

- 4) Crank engine, the display will show the DWELL ANGLE of points.

NOTE:

*Only traditional ignition system car that built in BREAKER POINTS needs to test DWELL ANGLE.
If the car in ELECTRONIC IGNITION SYSTEM need not.*

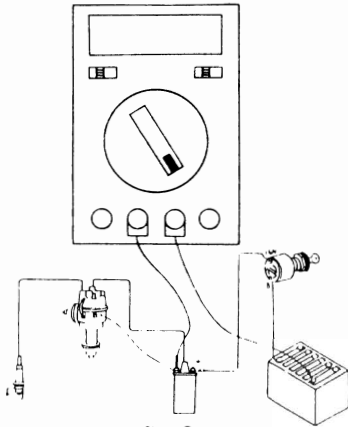

fig. 3

5-8 Continuity Beeper

- 1) Select the "Function Switch" to the "⌘)" " position.
- 2) Connect black test lead into "COM" terminal and red test lead into "OHM" terminal.
- 3) Connect test probes into circuit under test. If the resistance value of the circuit is less than approx. 100 OHM, then there will be Beeper sound output from the meter.

5-9 Diode Check

- 1) Select the "Function Switch" to the "→|" " position.
- 2) Connect red test lead to the "V" input terminal and black test lead into "COM" input terminal.
- 3) Connect test probes into circuit under test. If the resistance value to the circuit is less than approx. 100 OHM, then there will be Beeper sound output from the meter.

A. When connected with polarity as shown in Fig. 4, a forward current flow is established and the approx. DIODE forward voltage(VF) values in volt will display on the display reading. If the diode under test is defective, "000" or near ".000" value (short circuit) or "1" (open circuit) will be displayed.

B. When connected as shown in Fig. 5, a reverse check on the diode is made. If the diode under test is good, "1" will be displayed. If the diode under test is defective, "000" or other numbers will displayed. proper diode testing should include both steps A and B above.

5-10 OP ADPT./Optional Adapter (External Adapter)

A. EXT ADPT. (External adapter):

This range is exactly same as " DC 200 mV " range. it can match the external adapter (if this adapter is built-in DC 200 mV output), such as PHOTO TACH. TACHOMETER, LARGE CURRENT METER, THERMOMETER....

B. 200A (200A DC/AC CURRENT PROBE):

This range is exactly same as "DC 200mV" range. It can match the 200 A range of optional " DC/AC CURRENT PROBE" (such as CA-501, CA-202), then can get current values on the meter display directly.

C. 2000A (2,000A DC/AC CURRENT PROBE):

This range is exactly same as " DC 2V " range but without decimal point. It can match the 400 A or 2,000 A range of optional " DC/AC CURRENT PROBE " (such as CA-501, CA-202), then can get current values on the display directly.

D. BATT TEST (Battery tester):

This range is exactly same as " DC 200 V " range. It can match optional adapter of " BATTERY TESTER (with a load) ", then can test the battery condition.

6. REPLACEMENT OF BATTERY

- 1) When the left corner of LCD display show "BAT" or " ", it indicate a normal battery output of less than 6.5V – 7.5 V It is necessary to replace the battery. However, in-spec measurement may still be made for several hours after LOW BATTERY INDICATOR appears before the instrument become inaccurate.

- 2) Loose the Battery Cover Screw (3-7 Fig 1), slide the battery cover away from the instrument and remove the battery.
- 3) Replace with a 9V battery and reinstall the cover.
- 4) Make sure the battery cover is secured with the screw after changing battery.

7. OPTIONAL TEMPERATURE PROBE & OTHER ACCESSORIES

Temperature Probe (Type K) TP-01	Measure Range: -40 °C to 250 °C (-40 °F to 482 °F) Max. short-term operating temperature: 300°C (572°F) It is an ultra fast response naked bead thermocouple suitable for many general purpose application.
Temperature Probe (Type K) TP-02A	Measure Range: -50 °C to 900 °C (-50 °F to 1700 °F) Dimension: 10cm tube, 3.2mm dia.
Temperature Probe (Type K) TP-02B	General purpose application. Measure Range: -50 °C to 500 °C (-50 °F to 932 °F) Dimension: 10cm tube, 4.2mm dia. 10cm handle.
Temperature Probe (Type K) TP-03	Measure Range: -40 °C to 1200 °C (-40 °F to 2200 °F) Dimension: 10cm tube, 8mm dia.
Carry case, CA - 03	Dimension: 185 x 90 x 60mm (7.3 x 3.5 x 2.4inch) Weight : 70g (0.1 LB)
Plug, PL - 03	Plug available for measuring external transistor hFE
Test Lead, TL - 02A	High quality and better performance test lead with silicon rubber wire & alligator clip sets.